

SM-200 METAL ROOF SYSTEM



MATERIALS

.032 aluminum 24 gauge steel
.040 aluminum 22 gauge steel

SPECS

12", 16" or 18" O.C. 2" High Mechanically Seamed

UL-90

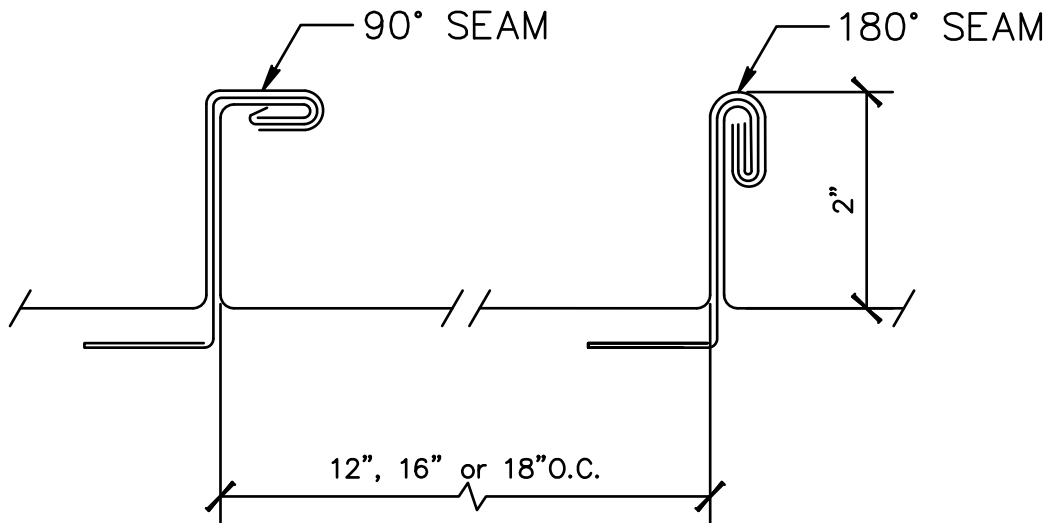
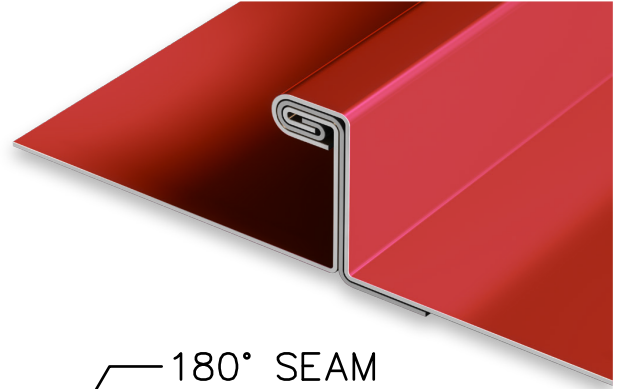

PRODUCT FEATURES

- ▶ Architectural/structural panel
- ▶ Factory-applied sealant available
- ▶ Continuous interlock
- ▶ Labor-saving one-piece design
- ▶ Stiffener beads upon request
- ▶ Striations upon request
- ▶ 30-year-non-prorated finish warranty
- ▶ Weathertightness warranty available

TESTING

- ▶ ASTM water & air tested
- ▶ ASTM-E84 tested (Class A Fire rating)
- ▶ ASTM-E1592 tested
- ▶ UL 580, Class 90
- ▶ Concentrated Load Tested
- ▶ UL 2218 Impact Test
- ▶ FM 4471

Note: UL 90 is available on steel panels up to 18" on center, and on aluminum panels up to 16" on center.